

PART NUMBER: 1604-6-2N-V

TITLE:

**3kW UHF / DTV 6 POLES BAND PASS FILTER (WITH FORCED AIR COOLING)
DUAL CROSS COUPLING UNCRITICAL MASK**

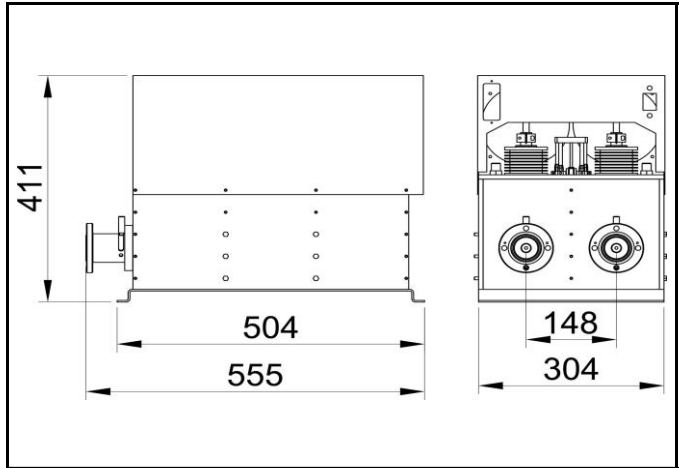

Tunable within whole UHF range.
For 6,7,8 MHz channel bandwidth.
DC block.
Different connectors on request.

Connectors: EIA 1 5/8"
Max operating temperature (C°): 70
Temperature stability (kHz/K): < 2
Weight (kg): 32

DVB-T2 / BVB-T @ 8 MHz	
Frequency Range (MHz)	470 ÷ 862
Insertion Loss (dB) @ fo	< 0,3
I.L. (dB) @ fo ± 3.805 MHz	< 1,35
I.L. (dB) @ fo ± 3.885 MHz	< 1,15
Attenuation @ fo ± 4.2 MHz (dB)	> 5 / >4
Attenuation @ fo ± 6 MHz (dB)	> 20
Attenuation @ fo ± 12 MHz (dB)	> 41
Return Loss (dB)	> 23 / >25
Input/Output Impedance (Ohm)	50
Maximum Input Power (W)	3000 (RMS)
Max. Group Delay Variation (ns)	350 / 300

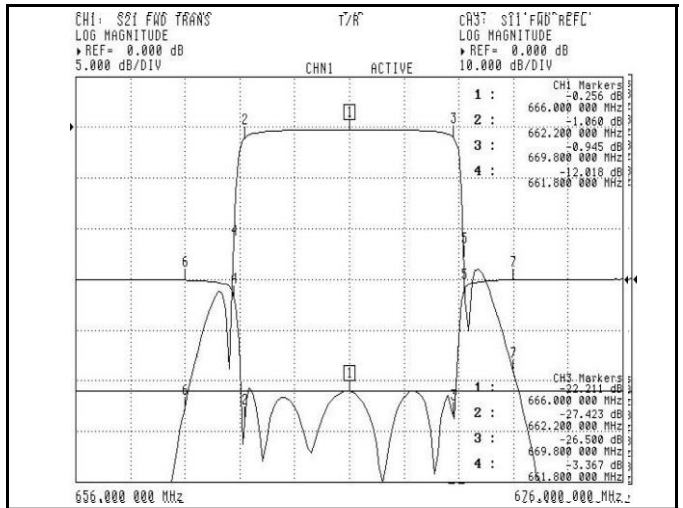

ISDB-T @ 6 MHz	
Frequency Range (MHz)	470 ÷ 862
Insertion Loss (dB) @ fo	< 0,35
Insertion Loss (dB) @ fo ± 2.79 MHz	< 1,1
Attenuation @ fo ± 3.15 MHz (dB)	> 8
Attenuation @ fo ± 4.5 MHz (dB)	> 24
Attenuation @ fo ± 9 MHz (dB)	> 54
Return Loss (dB)	24
Input/Output Impedance (Ohm)	50
Maximum Input Power (W)	2500 (RMS)
Max. Group Delay Variation (ns)	360

ATSC 3.0 / ATSC 1.0 @ 6 MHz	
Frequency Range (MHz)	470 ÷ 862
Insertion Loss (dB) @ fo	< 0,4
Insertion Loss (dB) @ fo ± 2.69 MHz	< 0,55
Insertion Loss (dB) @ fo ± 2.9 MHz	< 0,8
Attenuation @ fo ± 3.5 MHz (dB)	> 6 / > 10
Attenuation @ fo ± 6 MHz (dB)	> 29
Attenuation @ fo ± 9 MHz (dB)	> 63
Return Loss (dB)	26
Input/Output Impedance (Ohm)	50
Maximum Input Power (W)	2700 (RMS)
Max. Group Delay Variation (ns)	320 / 240